

IGK-DL 舵轮系列

IGK_DL系列型号说明

IGK DL 150 400 200 300

参考牵引重量 300kg

转向电机功率 200W

行走电机功率 400W

轮子直径 150mm

舵轮 DuoLun

爱极客 IGK

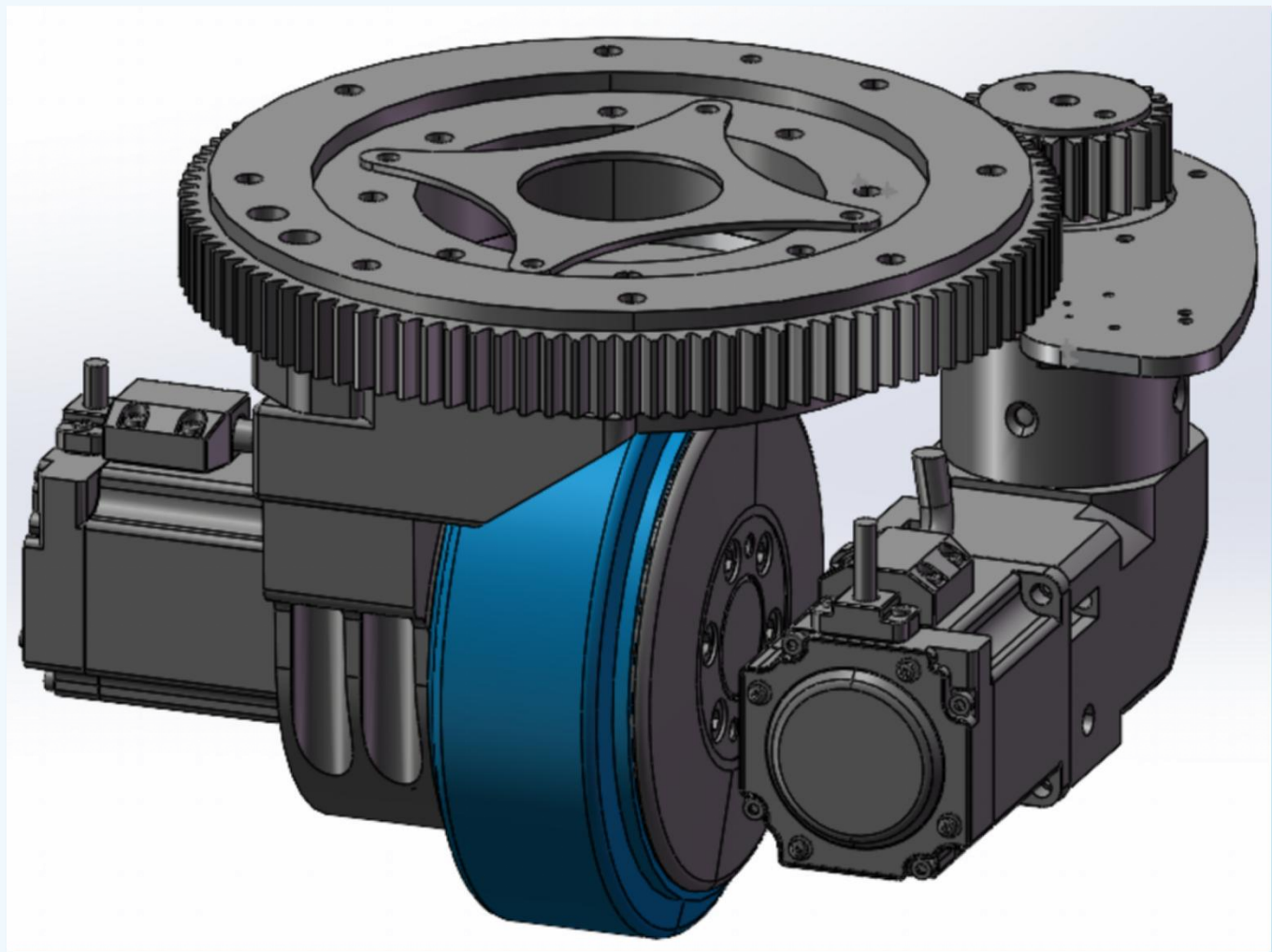

IGK-DL 舵轮系列

IGK-DL150-400-200-300

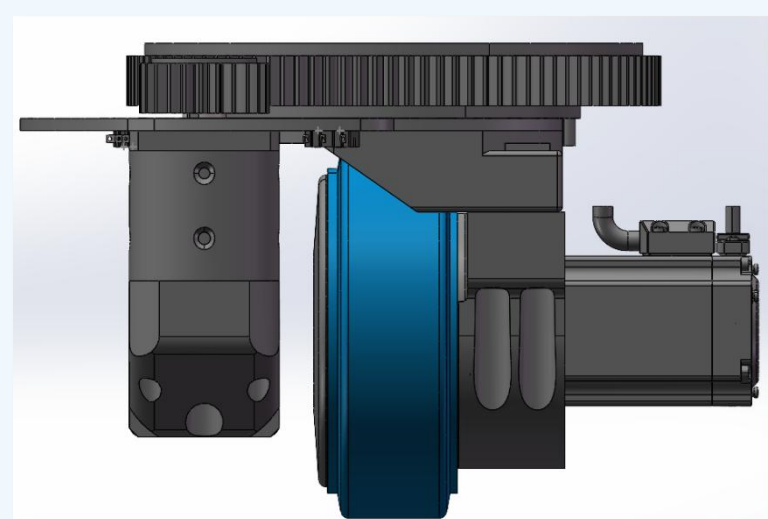
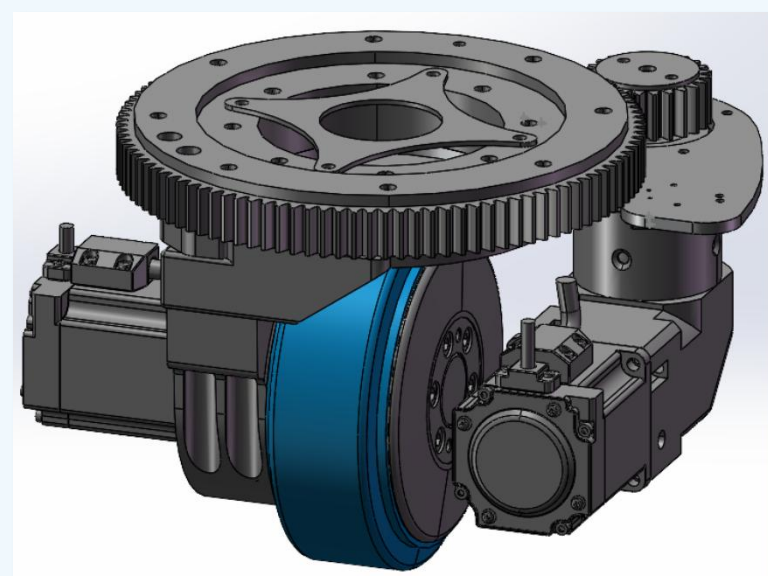

1		2		3	
		参数表 Technical Data			
A	行走部分 Driving	电机型号 Motor	LVM06004H3H3-M17		
		驱动器型号 Servo Driver	LD2-CAN7010		
		电机额定功率 Motor Rated Power	400W		
		电机额定电压 Motor Rated Voltage	48V(DC)		
		电机额定电流 Motor Rated Current	10A		
		电机额定转速 Motor Rated Speed	3000 rpm		
		电机额定扭矩 Motor Rated Torque	1.27Nm		
		电机防护等级 Motor Protection Level	IP65		
		电机编码器类型 Servo Encoder	17位多圈磁编码器		
		电机线长 Motor Cable Length	0.5m		
		行走减速比 Reduction Ratio	25		
		行走速度 Driving Rated Speed	56.52m/min		
		B	转向部分 Rotation	输出扭矩 Output Torque	29N·m
牵引力 Traction (Ref.)	386N				
参考牵引重量 Reference Traction weight	300kg				
电机型号 Motor	LVM06002H3H3-M17				
驱动器型号 Servo Driver	LD2-CAN7010				
电机额定功率 Motor Rated Power	200W				
电机额定电压 Motor Rated Voltage	48V(DC)				
电机额定电流 Motor Rated Current	6A				
电机额定转速 Motor Rated Speed	3000rpm				
电机额定扭矩 Motor Rated Torque	0.64Nm				
电机防护等级 Motor Protection Level	IP65				
电机编码器类型 Servo Encoder	17位多圈磁编码器				
电机线长 Motor Cable Length	0.5m				
行星减速器速比 Planetary Reducer Ratio	32				
回转支承齿数 Slewing Bearing Teeth	105	齿比 4.375:1			
转向齿轮齿数 Rotation Gear Teeth	24				
总转向速比 Total Reduction Ratio	140				
转向角度 Max Rotation Angle	±150°				
限位开关 Limit Switch	常闭				
零件代号					
借(通)用件登记					
描图					
描校					
旧底图总号					
底图总号					
签字					
日期					

